

# MW 35/27 - Mounting bracket

5040065

<https://www.phoenixcontact.com/us/products/5040065>

Please be informed that the data shown in this PDF document is generated from our online catalog. Please find the complete data in the user documentation. Our general terms of use for downloads are valid.



Plastic mounting bracket, with NS 35/7.5 DIN rail, to snap onto modular terminal blocks with a universal foot, profile length: 27 mm

## Commercial data

Item number	5040065
Packing unit	1 pc
Minimum order quantity	10 pc
Note	Made to order (non-returnable)
Sales key	BE64
Product key	BE64UX
GTIN	4017918167370
Weight per piece (including packing)	8.89 g
Weight per piece (excluding packing)	8.39 g
Customs tariff number	85369010
Country of origin	DE

# MW 35/27 - Mounting bracket

5040065

<https://www.phoenixcontact.com/us/products/5040065>

## Technical data

### Product properties

Product type	Assembly adapter
--------------	------------------

### Dimensions

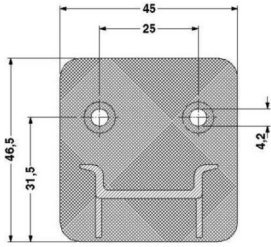
Dimensional drawing	
Width	45 mm
Height	27 mm
Depth	46.5 mm
Length	27 mm

### Material specifications

Flammability rating according to UL 94	HB
--	----

### Environmental and real-life conditions

#### Ambient conditions

Ambient temperature (operation)	-60 °C ... 85 °C
Ambient temperature (storage/transport)	-25 °C ... 55 °C (for a short time, not exceeding 24 h, -60 °C to +70 °C)
Ambient temperature (assembly)	-5 °C ... 70 °C
Ambient temperature (actuation)	-5 °C ... 70 °C
Permissible humidity (storage/transport)	30 % ... 70 %

# MW 35/27 - Mounting bracket

5040065

<https://www.phoenixcontact.com/us/products/5040065>



## Drawings

Dimensional drawing

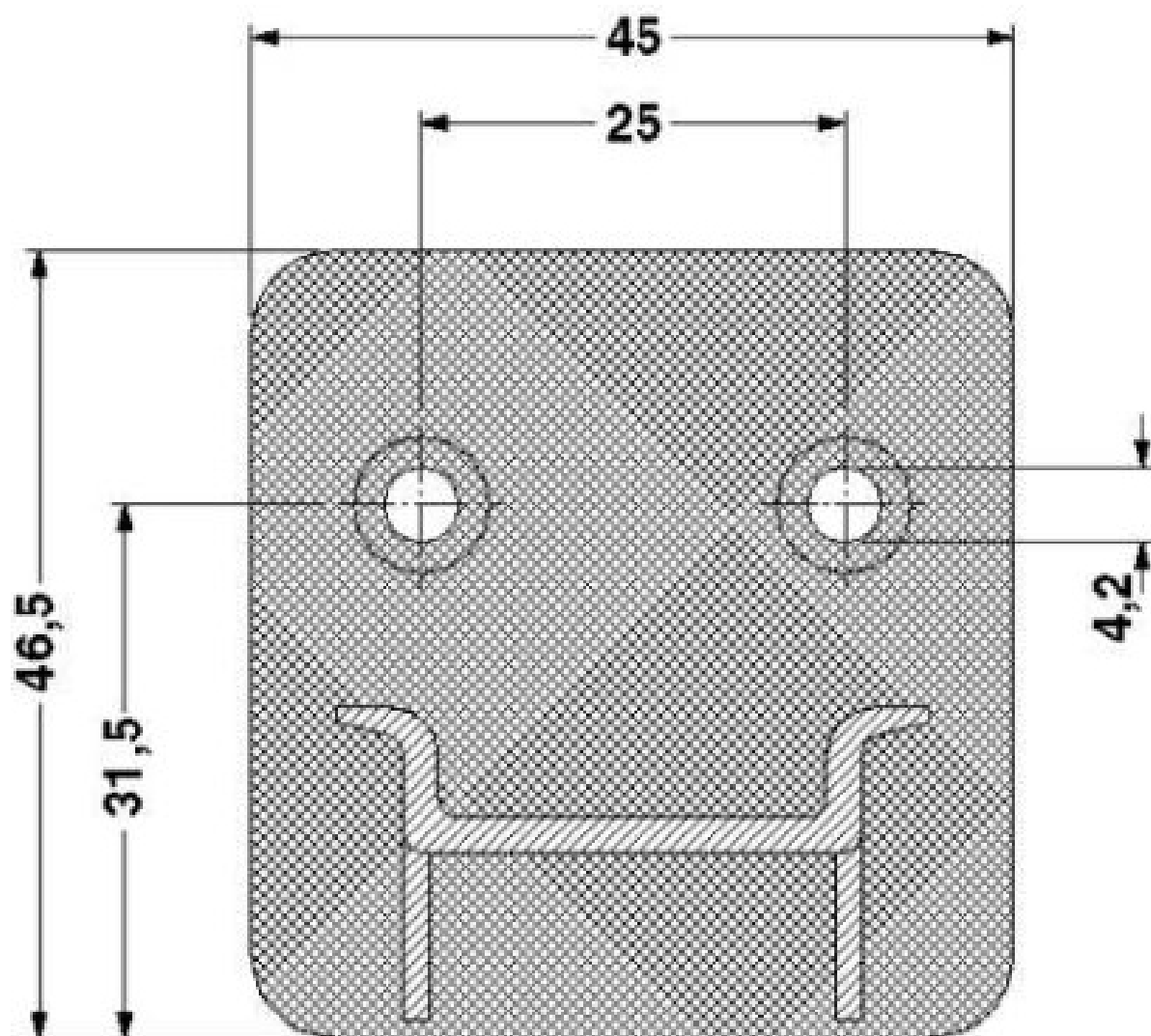

# MW 35/27 - Mounting bracket



5040065

<https://www.phoenixcontact.com/us/products/5040065>

## Classifications

### ECLASS

ECLASS-11.0	27141190
ECLASS-12.0	27141190
ECLASS-13.0	27141190

### ETIM

ETIM 9.0	EC002848
----------	----------

### UNSPSC

UNSPSC 21.0	39121400
-------------	----------

# MW 35/27 - Mounting bracket



5040065

<https://www.phoenixcontact.com/us/products/5040065>

## Environmental product compliance

China RoHS	Environmentally friendly use period: unlimited = EFUP-e No hazardous substances above threshold values
------------	---

Phoenix Contact 2023 © - all rights reserved  
<https://www.phoenixcontact.com>

Phoenix Contact USA  
586 Fulling Mill Road  
Middletown, PA 17057, United States  
(+717) 944-1300  
[info@phoenixcon.com](mailto:info@phoenixcon.com)